

BEHLEN®

SINGLE ROW STRIP JOINING PRESS

**MODEL "APSJ"
OPERATING INSTRUCTIONS & SERVICE INFORMATION**



NOTE: If pink sheets are included in this manual, refer to them for latest revisions.

BEHLEN®
4025 E. 23rd St.
Columbus, Nebraska 68601

**TECHNICAL
INFORMATION
61020**

IMPORTANT CONCERNS WHEN MOVING YOUR SPLICE DETECTION HOLE PUNCH FROM ONE DIE TO ANOTHER

In late 1997 we made a design change to our basic strip joining dies. This change involved making both upper and lower die shoes thicker by approximately 11/16" (17 ½ mm). This change also eliminated the mounting plates and made the entire unit more rigid.

This change also created a serious problem when a splice detection hole punch assembly is removed from an old style die and placed in a new style die. The result will be considerable damage to the entire die assembly. Do not, under any circumstances, remove a hole punch assembly from an old style die and place it in a new style die. Any damage resulting from this is excluded from any and all warranties.

To best determine whether you can interchange your hole punch assembly from one die to another, measure the thickness of the die shoe in both dies. If there is a thickness difference of more than 0.125" (3mm), please consult Behlen Mfg. Co. before proceeding.

SAFETY

 Watch for this symbol. It points out important safety precautions. It means "Attention - Be Alert! Your Safety Is Involved."

Several decals are attached to the press at various locations to call attention to your personal safety. Read and heed the message and be alert to possible injury or fatality.

It is your responsibility as a supervisor or operator to know what hazards exist and to make these known to all other personnel working the area so that they too may take any necessary safety precautions that may be required.

If the decal(s) become damaged or detached, contact your Behlen representative or the Behlen Mfg. Co. for replacements.

 Guards and shields are for your protection. Keep them in place and secure while machine is in operation.

 Replace safety shields that may have been damaged or removed for servicing purposes and fasten securely before operating machinery.

 Enforce the use of safety blocks whenever dies are being adjusted, repaired or replaced in the press.

 Before you perform any service on the press, make certain that the main power disconnect switch is locked in the off position.



PRE-OPERATIONAL PROCEDURE

The design and installation of any and all safety and guarding equipment for the passage of the metal strip through the Strip Joining Press that may be necessary to conform with O.S.H.A. or any applicable safety regulations to meet your particular line configuration are your responsibility, not that of Behlen Mfg. Co. Make the electrical connections according to the enclosed schematic.

In the event the press fails to operate the die (even though the pumps are running), it is possible the pump motor is running in reverse. Check the rotation. This situation can be corrected by interchanging any 2 of the 3 phase line leads.

Before each stitching operation, check the press to make sure the die is free of all foreign material.

BEHLEN STRIP JOINING PRESS SERVICE AND OPERATING INSTRUCTIONS

1. Oil level should be kept to near the top of the sight gauge. This machine was filled to the proper level at the factory with MOBIL DTE-26 hydraulic fluid unless otherwise specified.
2. Adjust stitch height switch for various thicknesses of material if necessary.
3. Lubricate the guide posts on the die as required. Keep the die area free of all foreign material.
4. Adjust the limit switch on the ram to coast to a stop at bottom of the cylinder stroke.

5. To perform the stitching operation, stop the trailing end of leading material, holding about 14" (35.5cm) in the machine. Next, insert 14" (35.5cm) of the leading end of the next coil, either above or below the trailing end. Push the "UP" control switch on the machine. In one cycle, the stitch is completed. During the cycle, the die will move up, make the stitch, reverse and stop in the original position. Check to be sure the limit switch shuts the press off at the finish of each stitch.
6. The Strip Joining Press can be cycled two or more times to form additional rows of stitches that may be required to obtain a holding stitch on lighter gauge material. This is accomplished by cycling the machine once, advancing the joined sheets forward out of the die area, and then cycling the machine again. For each additional row of stitches to be formed, overlap the coils approximately 14" (35.5cm) longer than required for row of stitches. Each cycle of the machine forms one row of stitches. A pre-cut strip (needle) can be inserted through one row of stitches if necessary, after two or more rows of stitches are formed, in order to obtain a holding stitch on lighter gauge material.
7. The relief valves are pre-set at the factory and should not be field adjusted.
8. THE STRIPPER PLATES AND/OR COMPLETE DIE SHOULD BE REMOVED PERIODICALLY AND THOROUGHLY CLEANED OF ALL CHIPS AND FOREIGN MATERIAL. THIS SHOULD BE DONE POSSIBLY ONCE A MONTH UNDER SEVERE CONDITIONS.

INSTRUCTIONS FOR ORDERING REPLACEMENT PARTS

In order to insure that the correct parts will be provided, all orders for replacement parts must include the serial number and model of the strip joiner. These numbers may be found on the name plates located on the die and on the press frame near the controls.

INSTRUCTIONS FOR SERVICING THE DIE

Reference to die teeth in the following procedure means punch.

For 18° angle on punch - part no. 616184.

DIE REMOVAL INSTRUCTIONS

1. Lock out machine.
2. Place wooden block (2 places) into die opening.
NOTE: Blocks need to be 3-3/8" (86mm) to 3-1/2" (89mm) in height
3. Loosen bottom bolts and remove from die.
4. Using a bottle jack each end of die, jack bottom die until wooden blocks contact upper die.
5. Place 1/2" (13mm) dia. round rods under raised die.
6. Loosen and remove top bolts from die.
7. Lower die set onto rods and remove bottle jacks.
8. Push die out onto die cart.
9. Reverse procedure to install die.

INSTRUCTIONS FOR SHARPENING TEETH

Remove the entire die from the press as a unit and separate it into a top and bottom die set. Keep all teeth attached to the die plates for ease of sharpening. The stripper plates and urethane stripper plugs must be removed before the teeth are ground. Grind teeth of the top and bottom as a unit. Teeth shall be ground on tops and both adjoining angled sides. The sides are ground at an angle of 9° or 18°, depending on machine model. This angle is not critical, however, both sides should be the same. The die may now be reassembled and placed back into the machine. The die and press

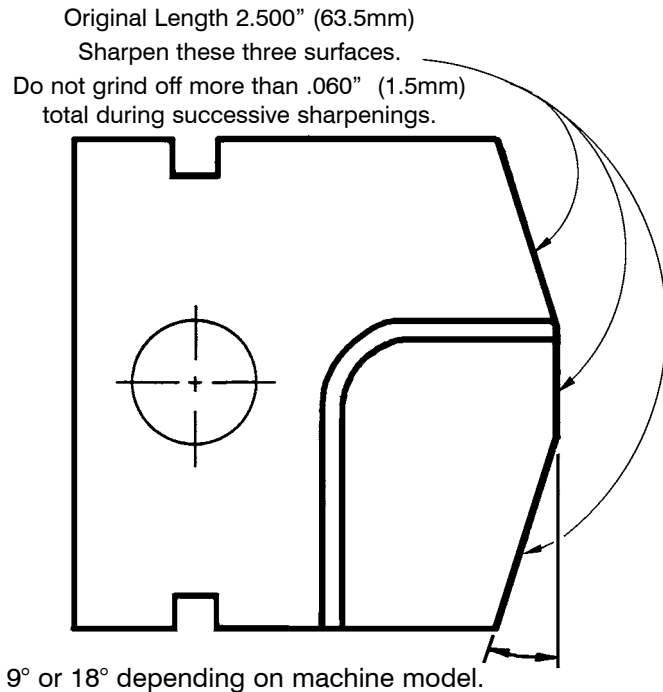

each have a marking labeled "Front". The die must be placed back in the press as originally assembled. If grinding equipment is not available to sharpen teeth as a unit, they may be ground individually. Read the instructions for the procedure to remove and replace teeth.

PROCEDURE FOR REPLACING TEETH OR OTHER PARTS OF THE DIE

Remove the die from the press as a unit and separate it into the top and bottom die sets. Next, remove the stripper plates and urethane stripper plugs, tooth clamps and rod. Teeth that need replacing may now be lifted off the die plate. In replacing new teeth, it is very important that all parts be cleaned thoroughly, making certain that no lint from wiping rags or other foreign material gets between the teeth. A spare tooth should be used for individually checking clearance between all teeth. This clearance should be .002" (0.05mm) minimum to .007" (0.18mm) maximum around all parts of mating teeth. After the clearance is determined to be correct, the teeth in the bottom die set should be securely fastened by means of the clamps and rod. The nuts on the rod should be tightened with a torque wrench to 120 foot pounds (163 N-M).

The teeth in the top die set should be tightened securely with the rod, but only tight enough with the clamps to hold them in place so they are allowed to move for adjustment after the top and bottom die sections have been slipped together. The top and bottom die sections should be slipped together without the urethane stripper plugs and stripper plates. At this time, clearance between top and bottom mating teeth should be checked and adjusted if necessary. After it is determined that the die meshes properly, the clamps of the top die should be tightened and the urethane stripper plugs and stripper plates replaced in the die. The entire die may now be returned to the press.

PROCEDURE FOR REPLACING CYLINDER SEAL

1. Remove the urethane roller (615 059) from one side of the press.
2. Remove the top and bottom bolts holding the complete die in place, and remove the complete die unit from the press.
3. Remove the screws that secure the ram plate to the pistons and then remove both ram plate skirts (616 113) and the ram plate (616 112).
4. Bolt a long bar or pipe to the piston (616 002) - there is one threaded hole in the top of each piston. Remove the piston upward from the cylinder (616 099).
5. Replace the defective seal (3308 009) in the cylinder, with the lips of the seal pointing downwards. Lubricate the seal for easier assembly.
6. Also, check the "O" - ring (2748 014#331), under the cylinder, for leakage and replace as required.
7. Reverse steps 1, 2, 3 and 4 to assemble. When replacing pistons, apply pressure downwards as evenly as possible so that lips of the seals will not be cut or damaged.

HOLE PUNCH FOR SPLICE DETECTION

For strip joining dies equipped with a hole punch assembly, 1½" or 2" (38mm or 51mm) diameter on the exit side of the die, you can sharpen the round punch portion and the die plate one or more times until a total of 0.075" to 0.100" (1.9mm to 2.5mm) maximum has been removed, depending upon the thickness of the material being joined. The following spare parts can be ordered by complete description and you must indicate the diameter of the hole punch, press model number and serial number.

1. Spare hole punch and die plate. (You will need to locate and drill dowel pin holes to properly match up the new mating punch and die plate.)
2. Urethane stripper ring (616270) over the hole punch for splice detection assembly.

OPERATION FOR BEHLEN STRIP JOINER PRESS

ILLUS. 1.1

STEP 1

FEED INCOMING EDGE OF COIL INTO DIE AREA AS SHOWN IN ILL. 1.1 OVERLAP MAY VARY DUE TO THE NEED FOR MORE ROWS OF STITCHES. STRIP EDGES SHOULD BE NO CLOSER THAN 1/2" (13MM) TO STRIPPER PLATE POCKETS AS SHOWN IN ILL. 1.2.

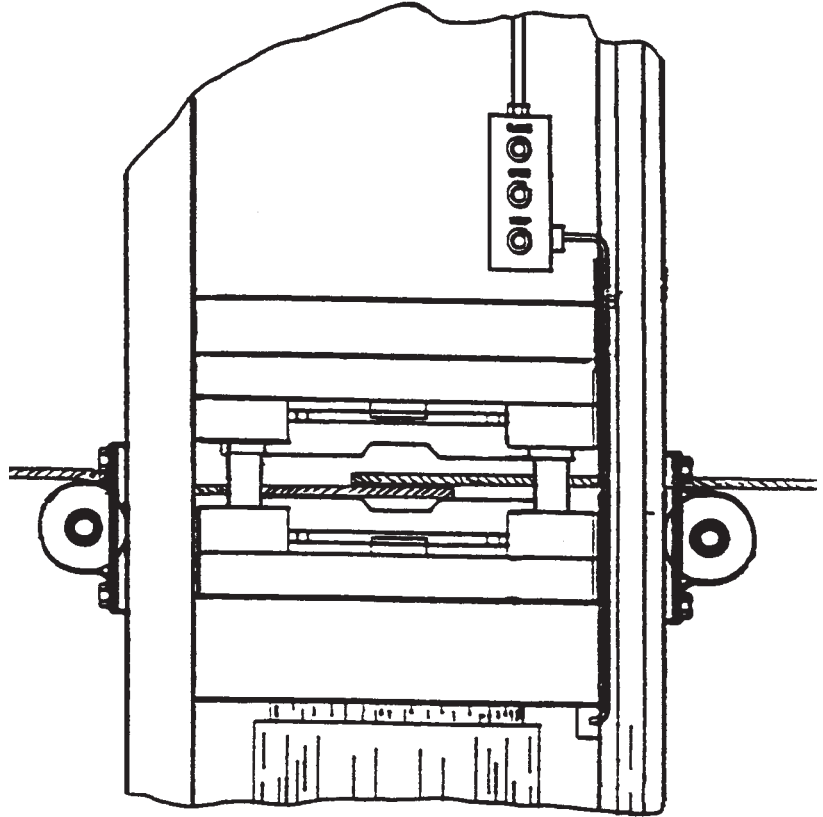

STEP 2

AFTER ALL CLEAR HAS BEEN ANNOUNCED FOR SAFETY PURPOSES, PRESS THE CLOSE BUTTON(S) FOR CYCLE ACTIVATION. THE MACHINE WILL RUN THROUGH COMPLETE CYCLE AND TURN OFF AUTOMATICALLY.

ILLUS. 1.2

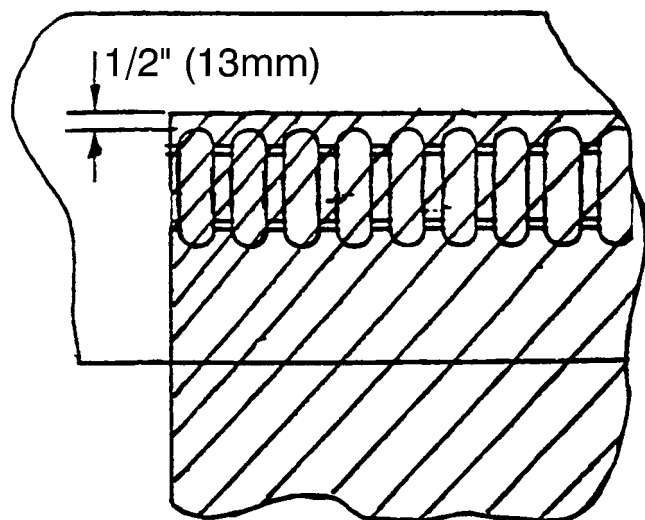

STEP 3

JOG THE JOINED MATERIAL COIL FOR LOCKING THE STITCHES.

FAIL TENSION DIAGRAM FOR TYPICAL STEEL & ALUMINUM

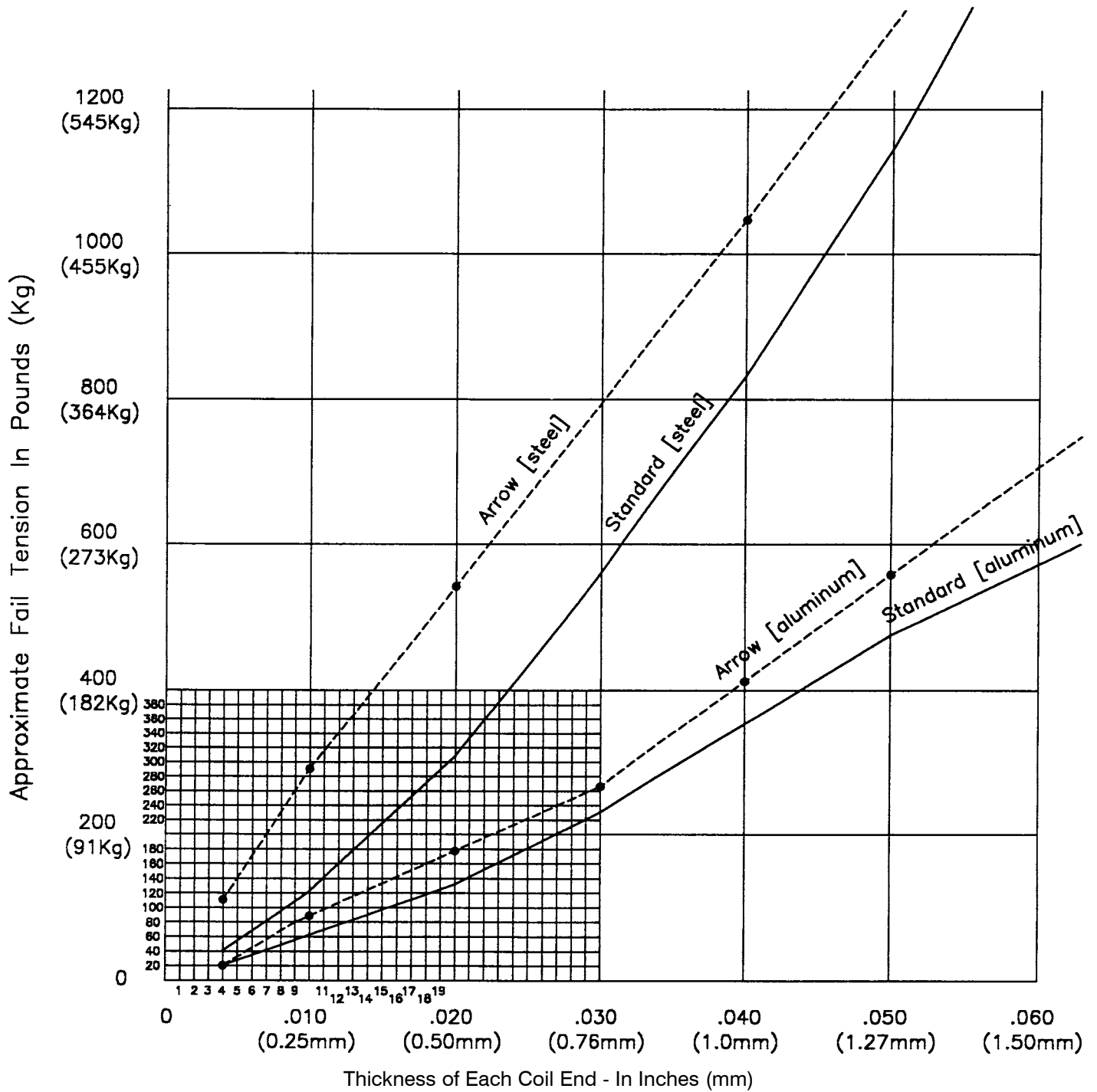

MILD STEEL 45,000 PSI (32 Kg/mm²) YIELD

ALUMINUM 5052 H-32 23,000 PSI (16 Kg/mm²) YIELD

Single Row Die - Read as pounds (Kg) per 1½" (38mm) of coil width.

Double Row Die - Multiply by 2 and read as pounds (Kg) per 1½" (38mm) of coil width.

Single Row Die with "W15T" as part of model number - Read as pounds (Kg) per 3" (76.2mm) of coil width.

Shift force is 25% of fail for steel and 60% for aluminum.

STITCH HEIGHT ADJUSTMENT

Adjust the depth switch as required to produce a good joint. The switch has been preset at the factory and, in most cases, will work for you. If adjustment of stitch height has been deemed necessary, each full turn will move the stitch height 0.025" (0.64mm). Adjust until satisfactory results are met. For a deeper stitch, turn adjustment wheel counter-clockwise. For a shallower stitch, turn adjustment wheel clockwise.

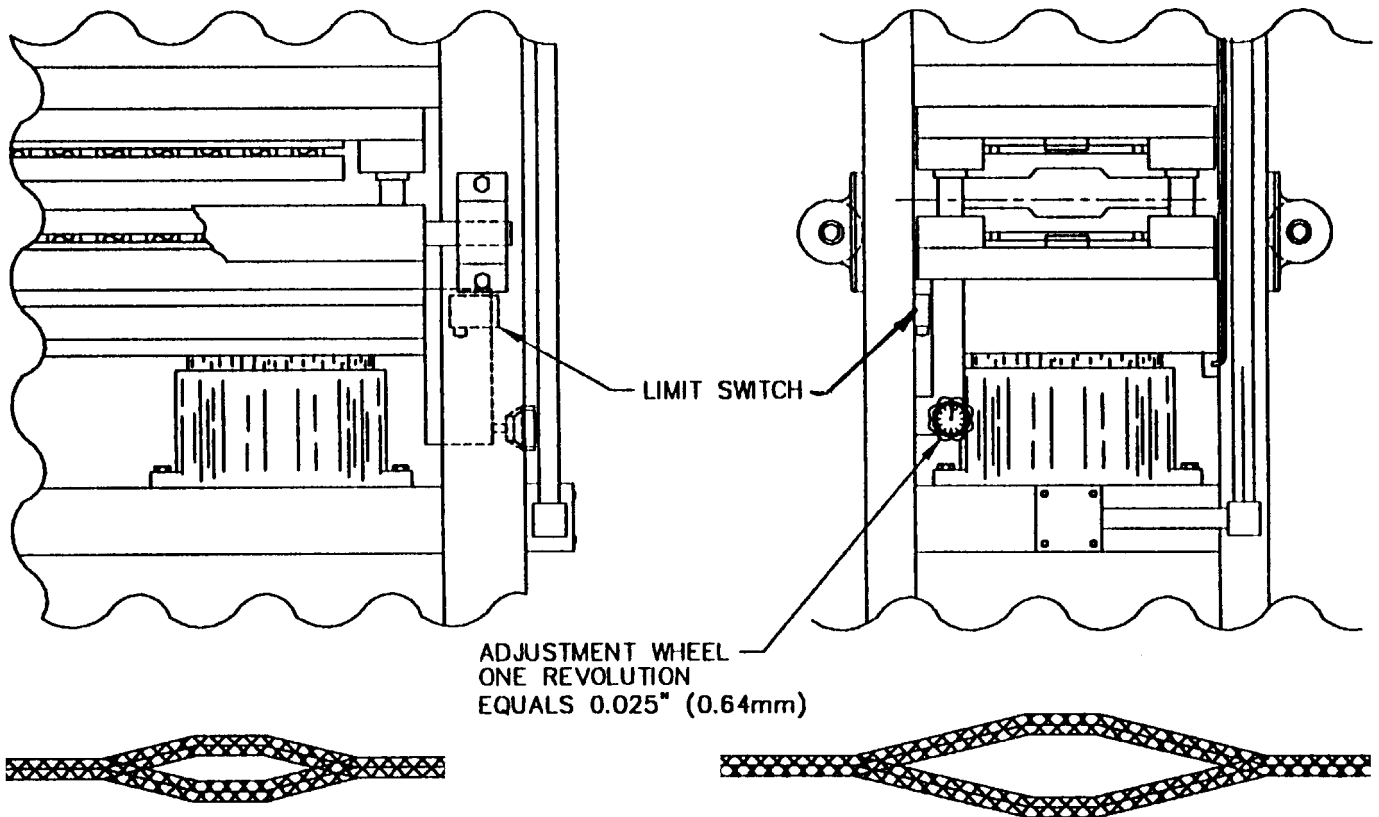

In this case, the stitch is incomplete. Turn the adjustment wheel counter-clockwise to make a deeper stitch.

In this case, the stitch is too deep causing the material to fracture. Turn the adjustment wheel clockwise to make a shallower stitch.

NUMBERED PARTS

Ref. Part No. Description

- 1 1328-092 Bolt, Rd. Hd. Stove 1/4" x 1/2"
- 2 1588-028 Connector, 3/4" St. Liquid Tight
- 3 1588-029 Connector, 3/4" x 90° Liquid Tight
- 5 1588-065 Connector, 1/2" x 90° Liquid Tight
- 6 1508-003 Clamp, 1/2" Conduit
- 7 1508-013 Clamp, 1" Conduit
- 8 1749-150 Conduit, 3/4" Liquid Tight
- 9 1749-110 Conduit, 1/2" Liquid Tight
- 10 1749-160 Conduit, 1 1/2" Liquid Tight
- 11 2688-022 Nut, Hex 5/8" NC
- 12 3188-039 Screw, Hex Hd. Cap 1/2" NC x 3"
- 13 2688-010 Nut, Hex 5/16" NC
- 14 3188-004 Screw, Hex Hd. Cap 1/2" NC x 1"
- 15 3248-037 Screw, Socket Hd. Cap 7/16"
- 16 3188-042 Screw, Hex Hd. Cap 5/16" NC x 3/4"
- 17 3188-066 Screw, Hex Hd. Cap 1/4" NC x 3/4"
- 18 3188-036 Screw, Hex Hd. Cap 1/2" NC x 1 1/2"
- 19 3188-037 Screw, Hex Hd. Cap 7/16" NC x 3"
- 20 1328-099 Bolt, Rd. Hd. Stove 3/16" NC x 1"
- 21 3208-055 Screw, Slot Rd. Hd. 3/16" NC x 2"
- 22 3248-002 Screw, Socket Hd. Cap 5/8" NC x 2"
- 23 3188-037 Screw, Socket Hd. Cap 7/16" NC x 3"
- 24 3248-012 Screw, Socket Hd. Cap 5/8" NC x 3"
- 25 1588-015 Connector, 1/2" x 90° Liquid Tight
- 27 3248-026 Screw, Socket Hd. Cap 1" NC x 2"
- 28 3248-009 Screw, Socket Hd. Cap 1/2" NC x 1/2"
- 29 3948-001 Washer, Wrought 5/16"
- 30 3948-002 Washer, Wrought 1/2"
- 31 3948-016 Washer, Wrought 1/4"
- 32 1788-030 Elbow, 1/2" x 90° Pulling
- 33 3948-028 Washer, Lock 1/2"
- 34 3948-019 Washer, Lock 5/8"

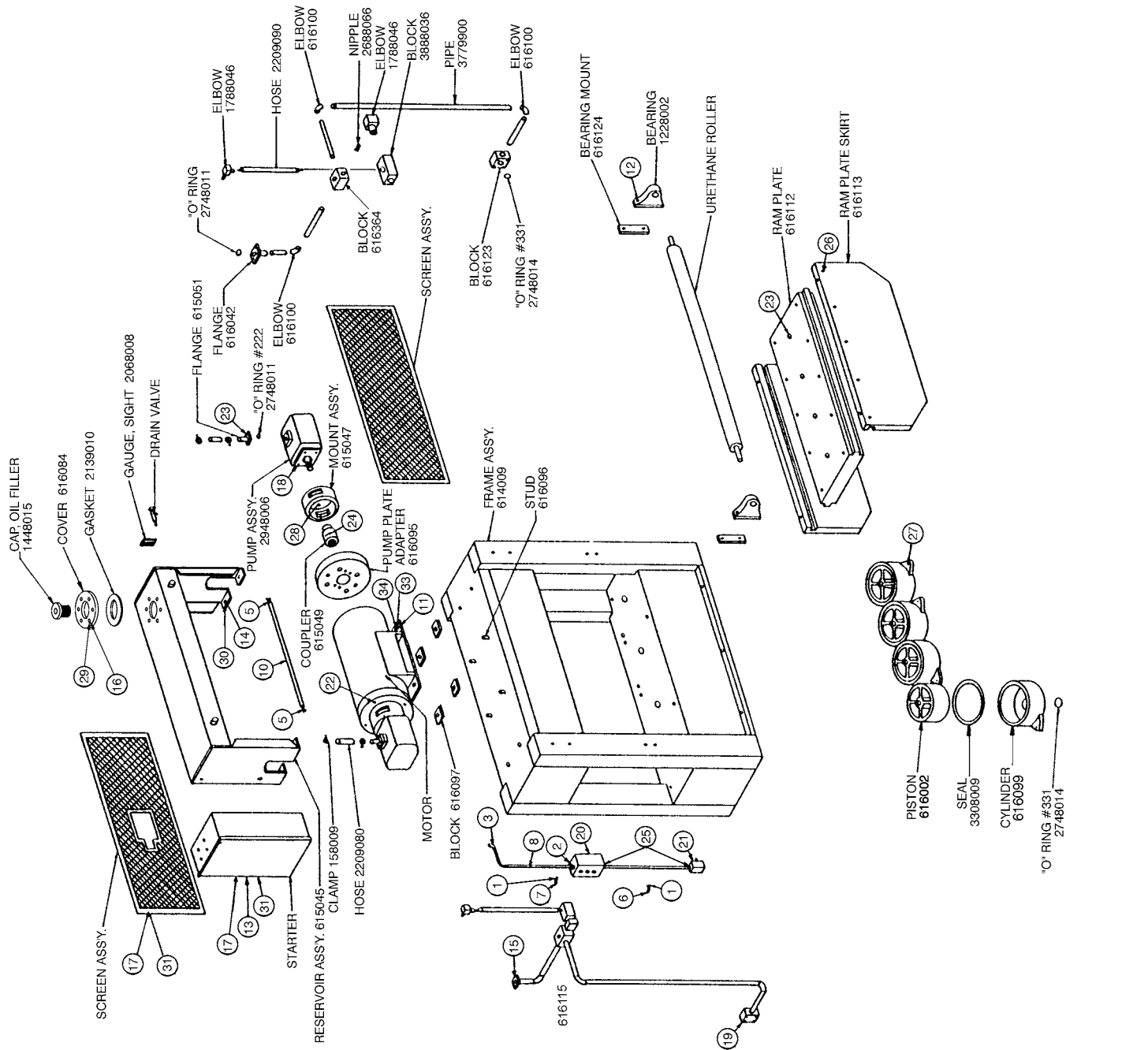

SINGLE ROW APSJ STITCHING DIE PARTS IDENTIFICATION

U.S. Patent No. 3,728,779
Foreign patents and Foreign patents pending.

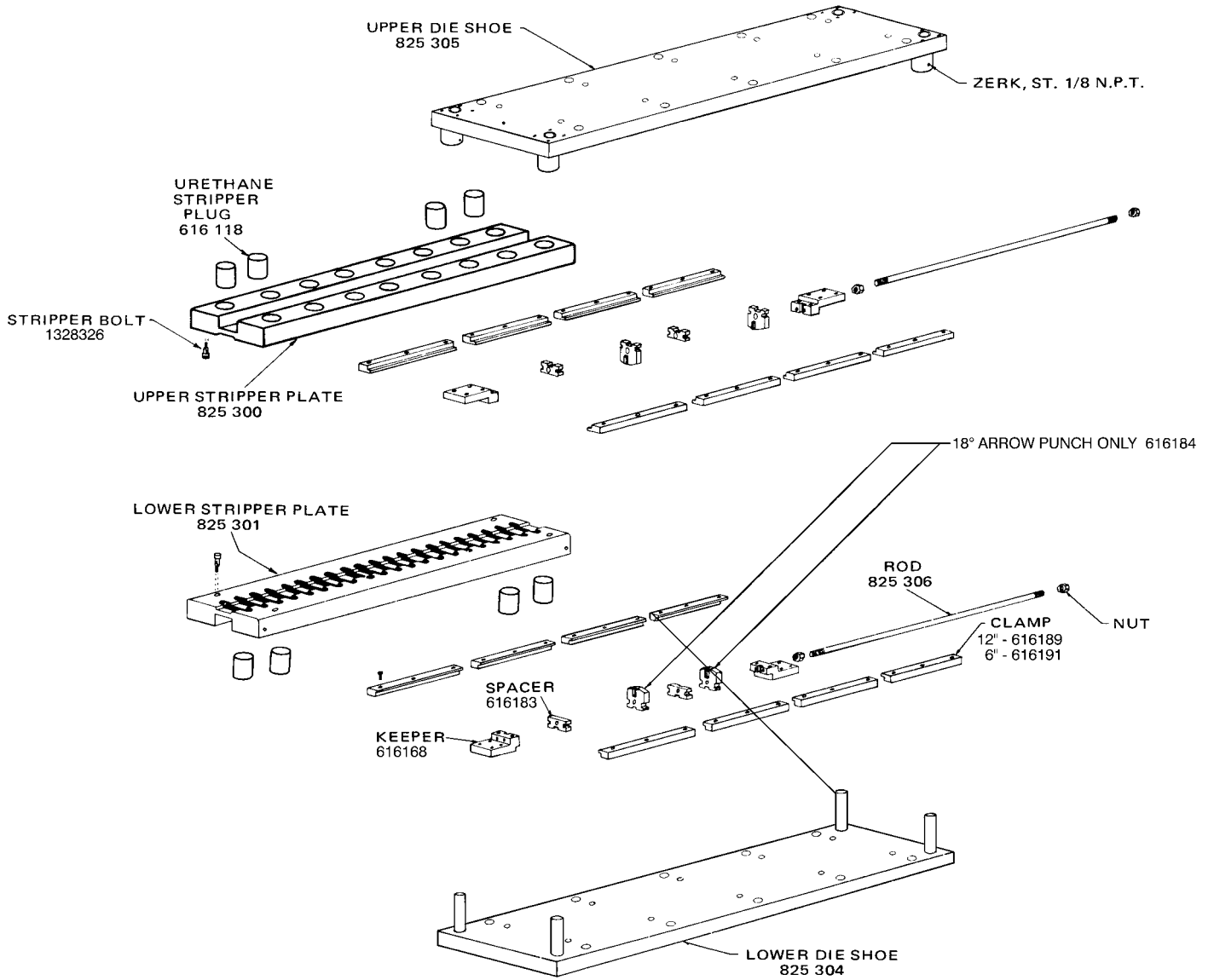

HYDRAULIC SCHEMATIC

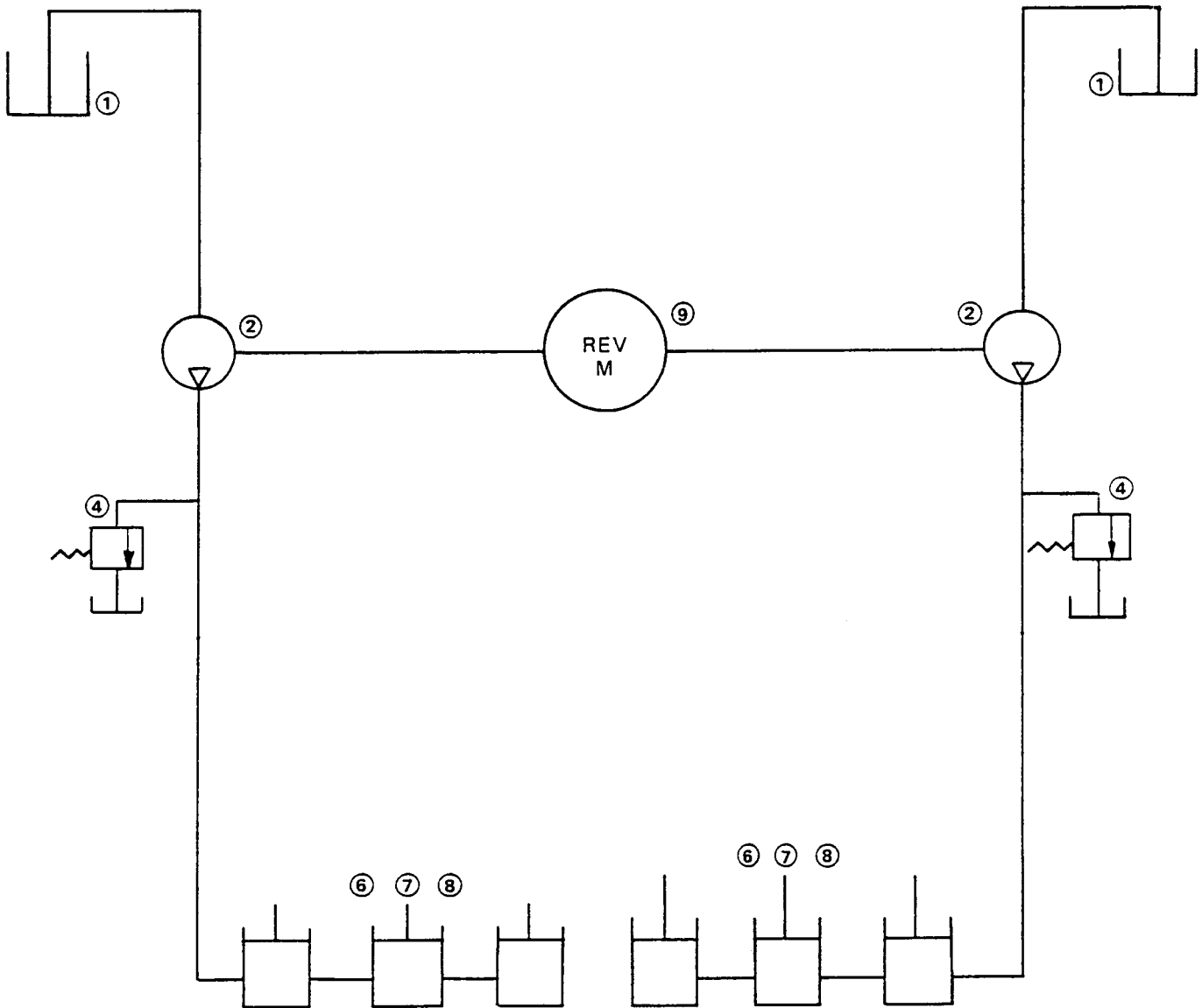

- (1) RESERVOIR
- (2) PUMPS
- (4) RELIEF VALVE
- (6) CYLINDER 2, 4, 6, or 8 of Each
- (7) PISTON Used Depending On
- (8) SEAL Machine Model
- (9) MOTOR

ELECTRICAL CIRCUIT

- 1 LS LIMIT SWITCH (DOWN)
- 2 LS LIMIT SWITCH (DEPTH SWITCH)
- 1 M, 2 M MOTOR STARTER (REVERSING)
- M1 INTERLOCK ON 1 M (NO-UP)
- M2 INTERLOCK ON 1 M (NC-UP)
- M3 INTERLOCK ON 2 M (NC-DOWN)
- M4 INTERLOCK ON 2 M (NO-DOWN)
- 1 MTR PRESS MOTOR
- 1 PB PUSHBUTTON STOP (NC)
- 2 PB-1 PUSHBUTTON UP (NO)
- 2 PB-2 PUSHBUTTON UP (NC)
- 3 PB-1 PUSHBUTTON DOWN (NO)
- 3 PB-2 PUSHBUTTON DOWN (NC)
- 1T TRANSFORMER CONTROL
- 1 TAS OVERLOAD SWITCH WOUND IN 1 MTR

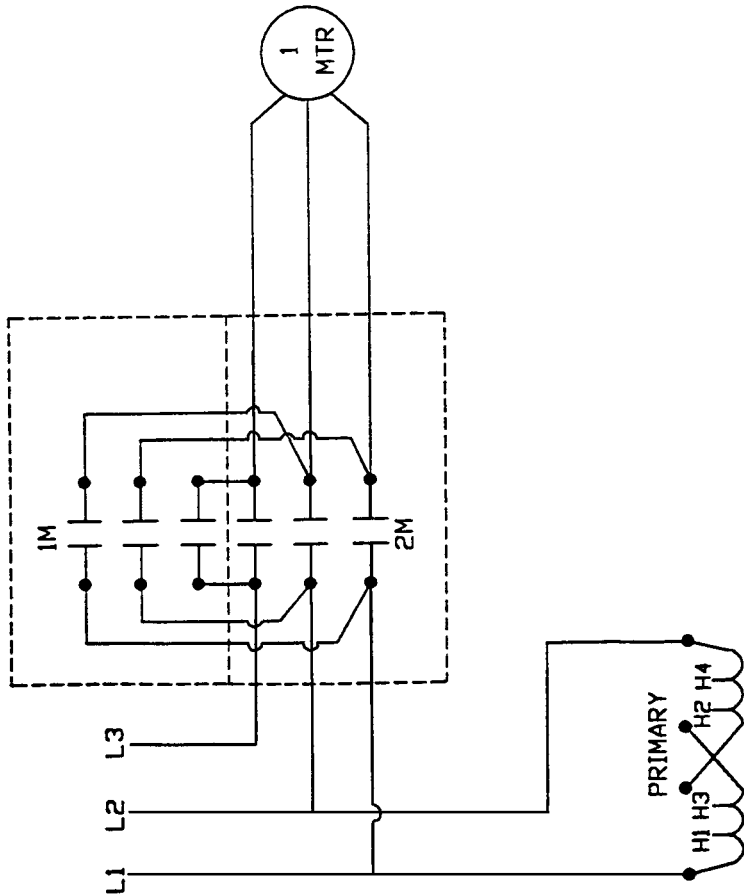

NOTE: 1 LS HAS ADDITIONAL CONTACTS (2 NO & 1 NC) THAT MAY BE USED FOR INTERLOCKING.

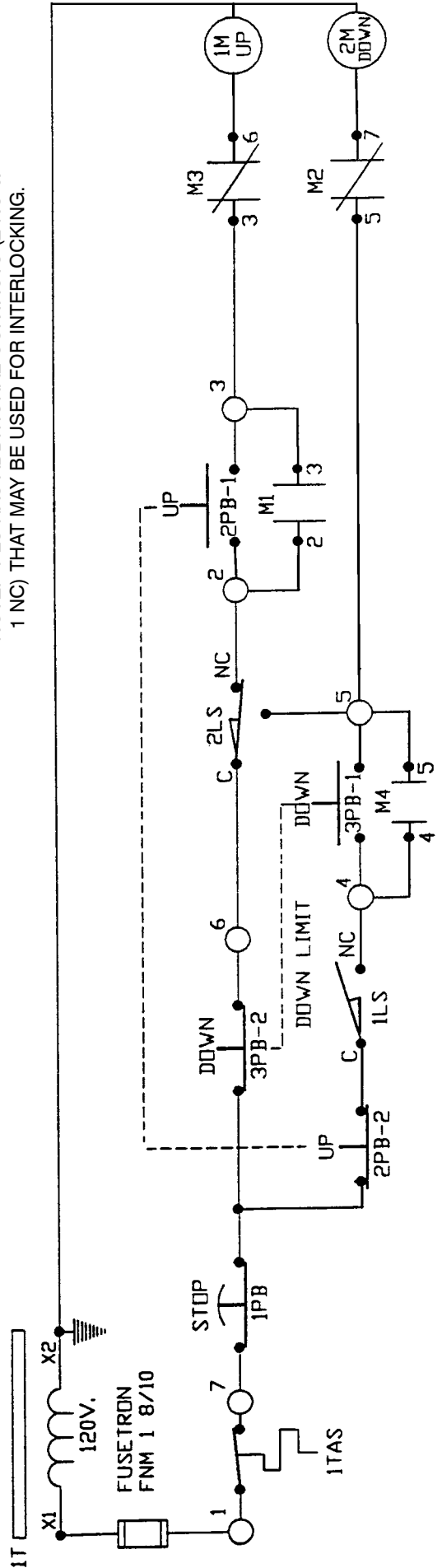

SERVICE CONDITIONS

Table 1

Standard Conditions	Eight hours per day, normal or light loading, clean @ 40°C (100°F) maximum ambient.
Severe Conditions	Twenty-four hour per day operation or shock loading, vibration, or in dirt or dust @ 40-50°C (100-120°F)
Extreme Conditions	Heavy shock or vibration, or dust.

LUBRICATION VOLUME

Table 3

NEMA (IEC) Frame Size	Volume in Cubic Inches (cm ³)
182 Thru 215 (112 - 132)	0.5 (8)
254 Thru 286 (160 - 180)	1.0 (16)
324 Thru 365 (200 -225)	1.5 (24)
404 Thru 449 (250 - 280)	2.5 (40)

LUBRICATION FREQUENCY

Table 2

BALL BEARINGS				
Speed	NEMA (IEC) Frame	Standard Conditions	Severe Conditions	Extreme Conditions
1800 RPM & Slower	182 (112) Thru 215 (132)	3 Years	1 Year	6 Months
	254 (160) Thru 365 (200)	2 Years	6 to 12 Months	3 Months
	404 (225) Thru 449 (280)	1 Year	6 Months	1 to 3 Months
3600 RPM	ALL	6 Months	3 Months	1 Month
ROLLER BEARINGS				
For Roller Bearings divide the time periods above by 2.				

REPLACEMENT BEARINGS

Your maintenance program will not be complete without including spare bearings. It must be remembered that the bearing is a wearable component and therefore must eventually be replaced. To insure that you are able to maintain original operation, we recommend the purchase of spares directly from Reliance Electric.

All bearings used in Reliance motors are subject to exact specifications and tests necessary to satisfy performance requirements. In this manner, it is possible to duplicate your present bearing. Markings on the bearings do not indicate complete specifications.

LUBRICATION OF BEARINGS

Motors covered by this Instruction Manual are equipped with several types of bearings. This description covers regreasable anti-friction bearings only. Non-regreasable ball bearings require no periodic maintenance. See I/M B-3654 for oil mist lubricated anti-friction bearings procedures.

GREASE LUBRICATED BEARINGS

This motor has been properly lubricated at the time of manufacture and it is not necessary to lubricate at time of installation unless the motor has been in storage for a period of six months or more.

Lubrication of anti-friction bearings should be done as a part of a planned maintenance schedule. The Recommended Lubrication interval should be used as a guide to establish this schedule.

Cleanliness is important in lubrication. Any grease used to lubricate anti-friction bearings should be fresh and free from contamination. Similarly, care should be taken to properly clean the grease inlet area of the motor to prevent grease contamination.

RECOMMENDED LUBRICANT

For motors operating in ambient temperatures shown below, use the following lubricant or its equal.

BALL BEARING MOTORS

OPERATING TEMP. -25°C (-15°F) to 50°C (120°)

CHEVRON OIL	SRI NO.2
EXXON	UNIREX N2
SHELL OIL CO.	DOLIUM BRB
TEXACO, INC.	PREMIUM RB

MINIMUM STARTING TEMPERATURE -60°C (-76°F)

SHELL OIL CO.	AEROSHELL 7
---------------	-------------

ROLLER BEARING MOTORS

OPERATING TEMP. -25°C (-15°F) to 50°C (120°F)

CHEVRON OIL	BLACK PEARL EP NO. 2
TEXACO, INC.	PREMIUM RB

LUBRICATION PROCEDURE

Reliance regreasable anti-friction bearings may be lubricated with the motor running or stationary. Stationary with the motor warm is preferred.

1. Locate the grease inlet, clean the area and replace the pipe plug with a grease fitting, if the motor is not equipped with grease fittings.
2. If motor is equipped with grease drain plug, remove plug and loosen any hardened grease that may block drain.
3. Add the Recommended Volume of the Recommended Lubricant using a hand operated grease gun.
4. Run the motor for two hours.
5. Replace the pipe plug in grease drain.
6. Grease may not relieve from drain. Use only volume shown in Table 3.

LUBRICATION INSTRUCTIONS

1. Select Service Condition from Table 1.
2. Select Lubrication Frequency from Table 2.
3. Select Lubrication Volume from Table 3.
4. Lubricate the motor at the required frequency with the required lubricant volume in accordance with LUBRICATION PROCEDURE.

NOTE: Mixing lubricants is not recommended due to possible incompatibility. If it is desired to change lubricant, follow instructions for lubrication and repeat lubrication a second time after 100 hours of service. Care must be taken to look for signs of lubricant incompatibility, such as extreme soupiness visible from the grease relief drain area, or from the shaft opening.

CROSS SECTIONAL AND PARTS IDENTIFICATION SECTION AND DRAWINGS.

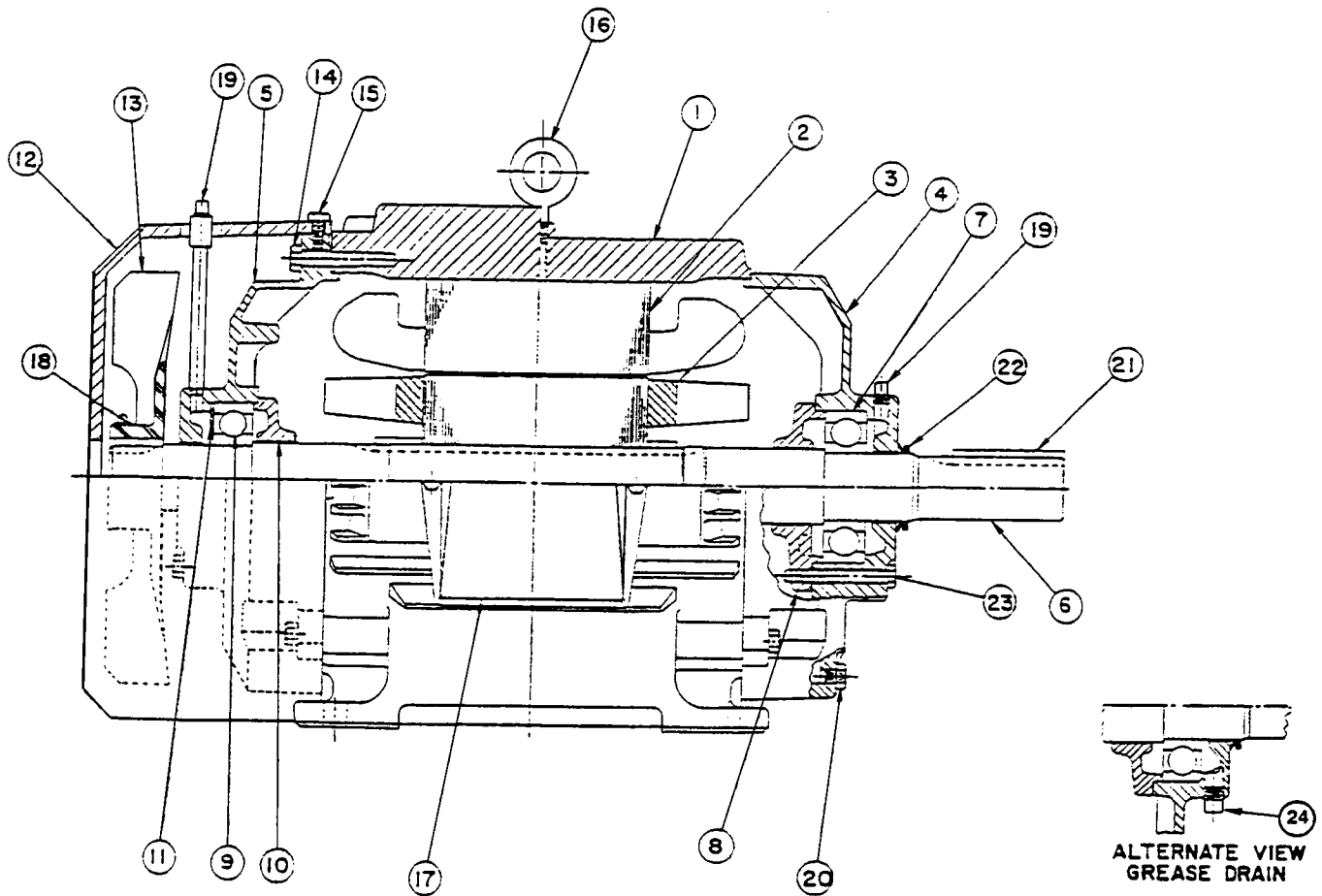

REF. NO.	PARTS DESCRIPTION
1	FRAME
2	STATOR
3	ROTOR/INTERNAL COOLING FAN
4	BACKEND BRACKET
5	FRONTEND BRACKET
6	SHAFT
7	BACKEND BALL BEARINGS
8	BACKEND INNER BERARINS
9	FRONTEND BALL BEARINGS
10	FRONTEND INNER CAP
11	WAVE WASHER, FRONTEND
12	FAN COVER
13	OUTER COOLING FAN

REF. NO.	PARTS DESCRIPTION
14	FRONT END BRACKET BOLTS
15	FAN COVER BOLTS
16	EYEBOLT
17	TERMINAL BOX
18	FAN CLAMP
19	GREASE ENTRY
20	CONDENSATION DRAIN
21	KEY
22	SLINGER
23	BACKEND CAP BOLTS
24	GREASE DRAIN